

**NEW**

# PiLoTREK WP-200

INTEGRATED 80 GHz (W-BAND) RADAR  
FOR LIQUIDS & SOLIDS



5 YEARS WARRANTY

# NIVELCO

LEVEL TRANSMITTERS

## FEATURES

- 2-wire 80 GHz (W-band) radar
- Measuring range up to 30 m (98.5 ft) for liquids
- Accuracy of  $\pm 2$  mm (0.078")
- Easy to install due to small antenna diameter
- 1", 1½" encapsulated horn antenna
- Integrated design with IP66 / IP68 protection
- User-friendly threshold management
- Configuration via Bluetooth® with MobileEView app
- PACTware™ compatible
- Ex variant

## APPLICATIONS

- For measuring the level of liquids, emulsions, and other media
- For large-particle bulk solids
- Storage tanks, chemical tanks, open pits, sumps, wells
- Measurement through a plastic tank roof
- For material prone to vapor formation
- For measuring liquids with a gas blanket
- It can also be used in a vacuum
- Open-channel flow measurement

## CERTIFICATES

- ATEX (Ex ia GD)
- IECEx (Ex ia GD)
- ANATEL

## AREAS OF APPLICATION

- Water and wastewater industry
- Energy industry / Plant utilities
- Food & Beverage
- Pharmaceutical industry
- Chemical industry
- Marine applications
- Agriculture
- Construction materials
- Heavy industry
- Packaging industry



WP□-2□2-4



WP□-2□4-4

The new **PiloTREK WP-200** non-contact radar level transmitters use the most advanced industrial measurement technology, the 80 GHz FMCW radar. The most fundamental advantage of 80 GHz radars compared to lower frequencies (5...12 GHz and 25 GHz) is the smaller antenna size, better focusability, and narrow beam angle.

It uses the latest technology for measuring liquids, masses, emulsions, and other chemicals widely used in, for example, the water industry, food industry, energy industry, pharmaceutical industry, and chemical industry, which provides measurement results with millimeter accuracy. It is also excellent for measuring substances prone to vapor formation and liquids with gas blanket or large-particle bulk solids. In addition to the level, volume, and weight measurement functions, this product family also inherits the open-channel flow measurement functions and the threshold functions to eliminate false and interfering echoes. Since no medium is required for millimeter waves to propagate, it can also be used in a vacuum. The device can also be operated with HART® compliant **NIVELCO EView2**, **MultiCONT** universal process controller, and **PACTware™** software, or programmed via Bluetooth® communication with the new **MobileEView** app.

## OPERATING PRINCIPLE

The reflection of the millimeter-waves is highly dependent on the dielectric constant of the medium. Therefore, the measured medium's dielectric constant ( $\epsilon_r$ ) must be over 1.9 for millimeter-wave level measurement. The measurement principle of a level transmitter with a millimeter-waves signal is based on measuring the reflection's time of flight.

Informative $\epsilon_r$ values							
Butane (C <sub>4</sub> H <sub>10</sub> )	1.4	Ethers	4.4	Gasoline	2.3	Methyl alcohol (CH <sub>3</sub> OH)	33.1
LP gas	1.6...1.9	Acetic acid (CH <sub>3</sub> COOH)	6.2	Bitumen	2.6	Glycol (C <sub>2</sub> H <sub>6</sub> O <sub>2</sub> )	37
Kerosene	2.1	Limestone	6.1...9.1	Carbon disulfide (CS <sub>2</sub> )		Nitrobenzene (C <sub>6</sub> H <sub>5</sub> NO <sub>2</sub> )	40
Crude Oil		Ammonia (NH <sub>3</sub> )	17...26	Clinker	2.7	Glycerin (C <sub>3</sub> H <sub>8</sub> O <sub>3</sub> )	41.1
Diesel Oil	2.2	Acetone (C <sub>3</sub> H <sub>6</sub> O)	21	Resin	2.4...3.6	Water (H <sub>2</sub> O)	80
Benzol (C <sub>6</sub> H <sub>6</sub> )		Ethyl alcohol (C <sub>2</sub> H <sub>5</sub> OH)	24	Cereal Grain	3...5	Sulphuric acid (H <sub>2</sub> SO <sub>4</sub> ) (T = 20 °C [68 °F])	84

The speed of propagation of millimeter-waves signals in the air, gases, and vacuum is almost constant regardless of temperature and medium pressure, so the measured distance does not depend on the physical parameters of the intermediate medium. The **PiloTREK WP-200** level transmitter is a continuous-wave frequency modulated radar (FMCW) operating at 80 GHz (W-band). The most obvious advantages of 80 GHz radars over lower frequency (5...12 & 25 GHz) radars are smaller antenna size, better focus, and smaller beam angle. A portion of the millimeter-wave continuous wave energy radiated by the level transmitter antenna is reflected from the measured surface, depending on the material to be measured. The distance of the reflecting surface is calculated with high accuracy by the electronics from the frequency shift of the reflected signal and converted into a distance, level, or volume signal by the electronics.

## TECHNICAL DATA

		PVDF housing WPB/WPT-2□□-□	PP housing WPA-2□□-□
Measured values		Distance; calculated values: level, volume, mass, flow	
Signal frequency		77...81 GHz (W-band)	
Measuring range <sup>(1)</sup>		0...30 m (0...98.5 ft)	
Minimum beam angle <sup>(1)</sup>		7°	
Lowest $\epsilon_r$ of medium		1.9	
Resolution		0.1 mm (.0039")	
Supply voltage		12...36 V DC	
Output	Analog	4...20 mA (3.9...20.5 mA); $R_{Lmax} = (U_S - 12 V) / 0.02 A$	
	Digital	Bluetooth® LE 5.1 (optional), HART® interface, loop resistance $\geq 250 \Omega$	
	Relay (optional)	SPDT 30 V / 1 A DC; 42 V / 0.5 A AC	
	Service interface	SAT-504-3 compatible; galvanically isolated; 3.3 V LVDS; max. 100 mA	
Measuring frequency		~ 1/s	
Antenna diameter <sup>(1)</sup>		1" (25.4 mm), 1½" (38.1 mm)	
Antenna material <sup>(1)</sup>		Encapsulated horn antenna (PP / PVDF / PTFE)	
Process temperature		-40...+80 °C (-40...+176 °F)	-30...+80 °C (-34.4...+176 °F)
Ambient temperature			
Process pressure		-1...3 bar (-14.5...43.5 psi)	
Process connection		1", 1½" BSP / NPT	
Ingress protection		IP66 / IP68	
Electrical connection		4 × 0.5 mm <sup>2</sup> shielded Ø6 mm cable × 5 m (up to 30 m); For relay option: 7 × 0.5 mm <sup>2</sup> shielded cable [4× AWG22 shielded Ø0.24" cable × 16.4 ft (up to 98.5 ft); For relay option: 7× AWG22 shielded cable]	
Electrical protection		Overvoltage Class 1; (Class III [SELV])	
Housing material <sup>(1)</sup>		Plastic (PP / PVDF)	
Weight		~ 600 g (~ 1.32 lb)	

<sup>(1)</sup> Depending on order code.

## TYPE-DEPENDENT DATA

	WP□-212-□ WP□-213-□	WP□-214-□ WP□-215-□	WP□-224-□ WP□-225-□
Dead zone <sup>(2)</sup>	0 m		
Maximum measuring range <sup>(3)</sup>	10 m (33 ft)		20 m (66 ft)
Accuracy <sup>(4)</sup>	±5 mm (.197")		±2 mm (.078")
Beam angle (-3 dB)	12°		7°
Antenna insertion length <sup>(5)</sup>	56 mm (2.2")		70 mm (2.75")
Lower process connection	1" BSP / NPT		1½" BSP / NPT
Upper process connection	1" BSP		

<sup>(2)</sup> Measured from the tip of the antenna.

<sup>(3)</sup> May be limited in the case of low dielectric constant or non-perpendicular or non-planar media.

<sup>(4)</sup> In the case of an ideal reflecting surface.

<sup>(5)</sup> Measured from the sealing plane of the process connection.

## Ex INFORMATION

	WP□-2□□-8 Ex, WP□-2□□-E Ex	
Ex marking (ATEX)	⊕ II 1 G Ex ia IIC T5 Ga	⊕ II 1 D Ex ia IIIC T95°C Da
Ex power supply, intrinsic safety data <sup>(6)</sup>	$U_i = 30 \text{ V}, I_i = 100 \text{ mA}, P_i = 0.75 \text{ W}$	$U_i = 30 \text{ V}, I_i = 140 \text{ mA}, P_i = 1 \text{ W}$
	$C_i \leq 12 \text{ nF} + 0.12 \text{ nF/m cable}, L_i \leq 238 \text{ } \mu\text{H} + 0.65 \text{ } \mu\text{H/m cable}$ with standard 5 m cable: $C_i \leq 12.5 \text{ nF}, L_i \leq 242 \text{ } \mu\text{H}$	

<sup>(6)</sup> In IIB applications, Ex power supply data for IIIC can be used.

## TEMPERATURE DATA FOR Ex CERTIFIED MODELS

	WP□-2□□-8 Ex, WP□-2□□-E Ex	
	Hazardous gas atmospheres	Explosive dust atmospheres
	Ex ia IIC	Ex ia IIIC
Temperature data	Ex ia IIC	Ex ia IIIC
Temperature class	T5	T95°C
Highest ambient temperature	+80 °C (+176 °F)	
Highest surface temperature of the instrument <sup>(7)</sup>		

<sup>(7)</sup> Conducted or radiated heat transferred by medium, ambient or process connection.

## POLARIZATION

The PilotREK W-200 80 GHz radar is much less sensitive to installation conditions, both in terms of polarization and clutter sensitivity, due to its narrow and nearly circular beamwidth.

## BACKGROUND MAPPING

Thanks to its 80 GHz FMCW technology, it is much less sensitive to the presence of clutter than previous generation radars. It now has an easy-to-use, flexible threshold management (EView2) that allows echoes from clutter in the tank to be easily masked if necessary. The threshold curve is designed to mask unwanted echoes from the measurement. Echo peaks below the threshold are not included in the evaluation.

## WIRING

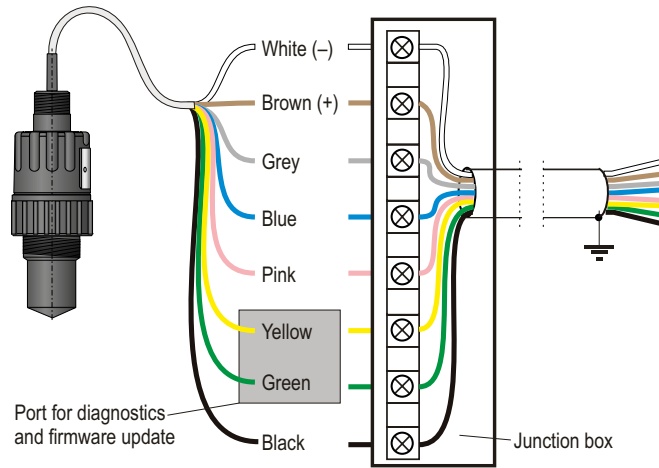

The **BROWN (+)** / **WHITE (-)** wires are the 4...20 mA output or power supply. The **GREY**, **BLUE** and **PINK** wires are for relay output and are only available in relay version. The **YELLOW** and **GREEN** wires are for servicing purposes only and are hidden by default. The **BLACK** is the cable shielding.

## MOUNTING

The device must not be mounted in the middle of the tank or the inlet's proximity or the tank's outlet to avoid unwanted multiple reflections. The ideal position for the PiloTREK is on the  $r = (0.3...0.5) R$  in a cylindrical tank. The device must be mounted far as possible from interfering objects inside the tank and sources of interference, such as waves, vortex or strong vibrations. The antenna cover must be parallel to the measured surface within  $\pm 2...3^\circ$ . The instrument must be protected from direct sunlight to avoid overheating.



## PC CONNECTION

The PiloTREK WP-200 series, equipped with HART® connectivity, offers enhanced functionality for industrial monitoring. Instruments can be connected to a PC using a UNICOMM SAK-305 HART®-USB modem, allowing users to visualize all measured values on the PC screen. This feature is crucial for real-time data monitoring and analysis. Additionally, the HART® modem enables remote programming and configuration of the instruments, providing flexibility and ease of use.

A notable feature of the HART® system is its ability to support up to 15 non-Ex (*non-explosive environment*) instruments on a single loop, making it ideal for large-scale operations. The system's compatibility with EView2 configuration software and NIVISION process visualization software further enhances its functionality, offering robust tools for effective process monitoring and control in various industrial settings.

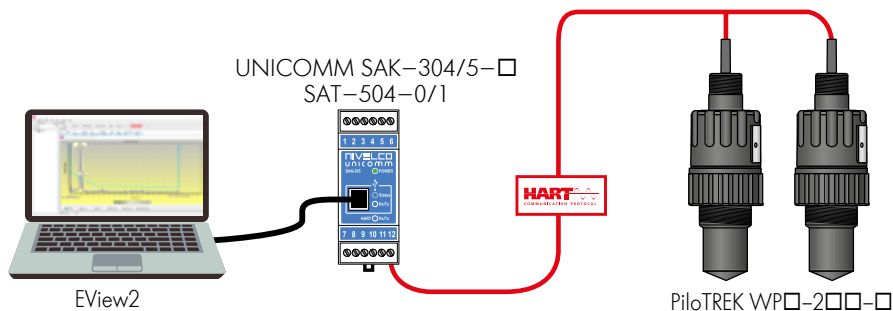

## Bluetooth® CONNECTIVITY

The **PiloTREK WP-200** level transmitter can be connected to a PC or cell phone via Bluetooth® wireless technology for configuration using **EView2** and **NIVISION** software or the new **MobileEView** app. **WP□-2□□-B/-C/-E/-R/-J** devices can be connected directly, and **WP□-2□□-4/-5/-8/-H/-F** devices can be connected using a **UNICOMM SAT-504-2** modem. This range of models and connectivity options makes the **PiloTREK WP-200** series adaptable for various industrial and monitoring applications.

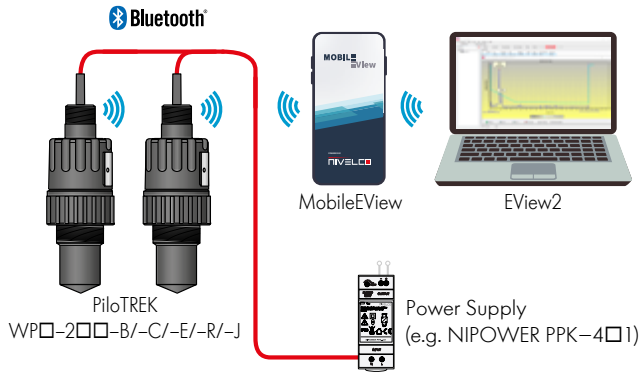

*In the system shown, the SAT-504-2 modem must be used in passive HART® modem mode! Do not activate the built-in power supply of the modem while the transmitters are powered!*

## HART® MULTIDROP LOOP

**MultiCONT** multi-channel process controllers process and display measurement data provided by NIVELCO's HART®-equipped transmitters in a multidrop loop. Connected transmitters can be programmed through **MultiCONT**, and it can also perform data logging tasks. Processed data can be sent to a computer via RS485 and displayed in **NIVISION**. **MultiCONT** provides the means to optimize and configure measurements and display the echo maps of the respective installations.

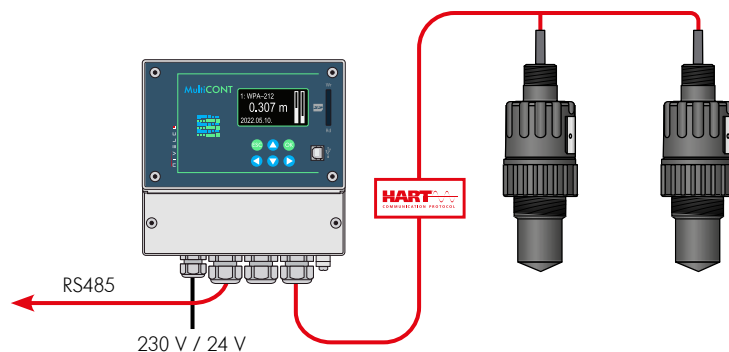

APPLICATIONS

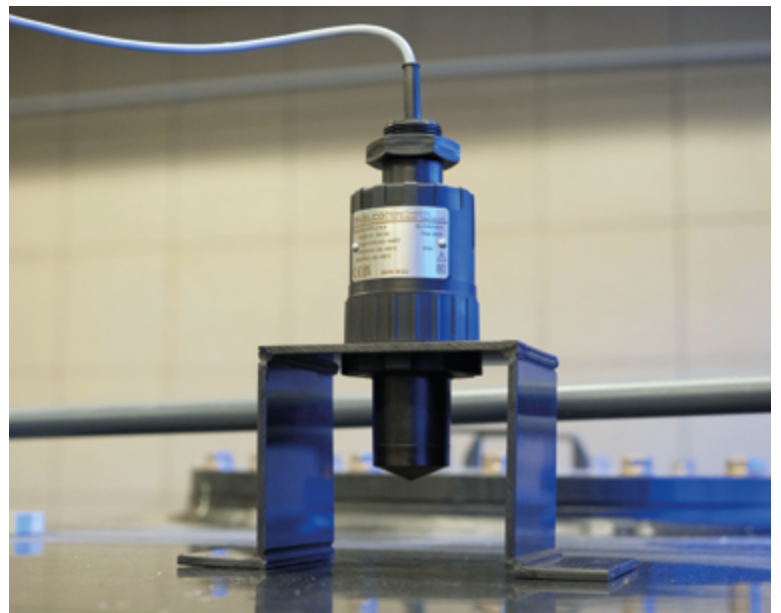

## DIMENSIONS

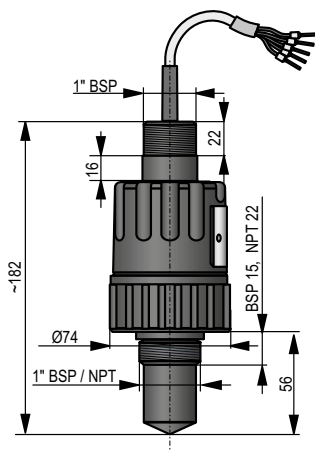

WP□-212-□, WP□-213-□

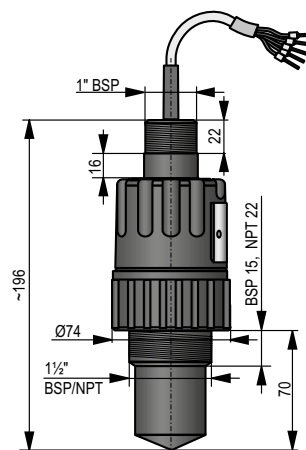

WP□-2□4-□, WP□-2□5-□

## ORDER CODES

(NOT ALL COMBINATIONS AVAILABLE)

### Advanced 80 GHz radar level transmitters

#### PiloTREK WP□ - 2□□ - □<sup>(1)</sup>

Integrated type	Antenna / Housing material	Code	80 GHz	Measurement distance	Code	Process connection - lower / upper	Code	Output / Ex	Code
	PP / PP	A		10 m (33 ft)	1	1" BSP / 1" BSP <sup>(3)</sup>	2	-	4
	PVDF / PVDF	B		20 m (66 ft)	2	1" NPT / 1" BSP <sup>(3)</sup>	3	Ex ta D <sup>(2)</sup>	5
	PTFE / PVDF	T		30 m (98.5 ft) <sup>(2)</sup>	3	1½" BSP / 1" BSP <sup>(4)</sup>	4	Ex ia	8
						1½" NPT / 1" BSP <sup>(4)</sup>	5	+ Relay	H
						2" BSP / 1" BSP <sup>(2,5)</sup>	6	+ Relay / Ex ta D <sup>(2)</sup>	F
						2" NPT / 1" BSP <sup>(2,5)</sup>	7	+ Bluetooth®	B
						Ø75 mm (2½") / 1" BSP <sup>(2,6)</sup>	8	+ Bluetooth® / Ex ta D <sup>(2)</sup>	C
								Bluetooth® / Ex ia GD	E
								+ Relay + Bluetooth®	R
								+ Relay + Bluetooth® / Ex ta D <sup>(2)</sup>	J



Use the NIVELCO Selector to configure your PiloTREK to best suit your application.

<sup>(1)</sup> The order code of an Ex version product should end in "Ex".

<sup>(2)</sup> Under development.

<sup>(3)</sup> Only for 10 m (33 ft) measuring range.

<sup>(4)</sup> Only for 10 m (33 ft) or 20 m (66 ft) measuring range.

<sup>(5)</sup> Only for 20 m (66 ft) measuring range.

<sup>(6)</sup> Only for 30 m (98.5 ft) measuring range.

The project 2020-1.1.2-PIACI-KFI-2021-00278 was funded by the Ministry of Culture and Innovation through the National Research Development and Innovation Fund, under the Market-driven Research, Development and Innovation Projects (2020-1.1.2-PIACI-KFI) call for proposals.

